

# Hytorc-Stealth sprängskiss

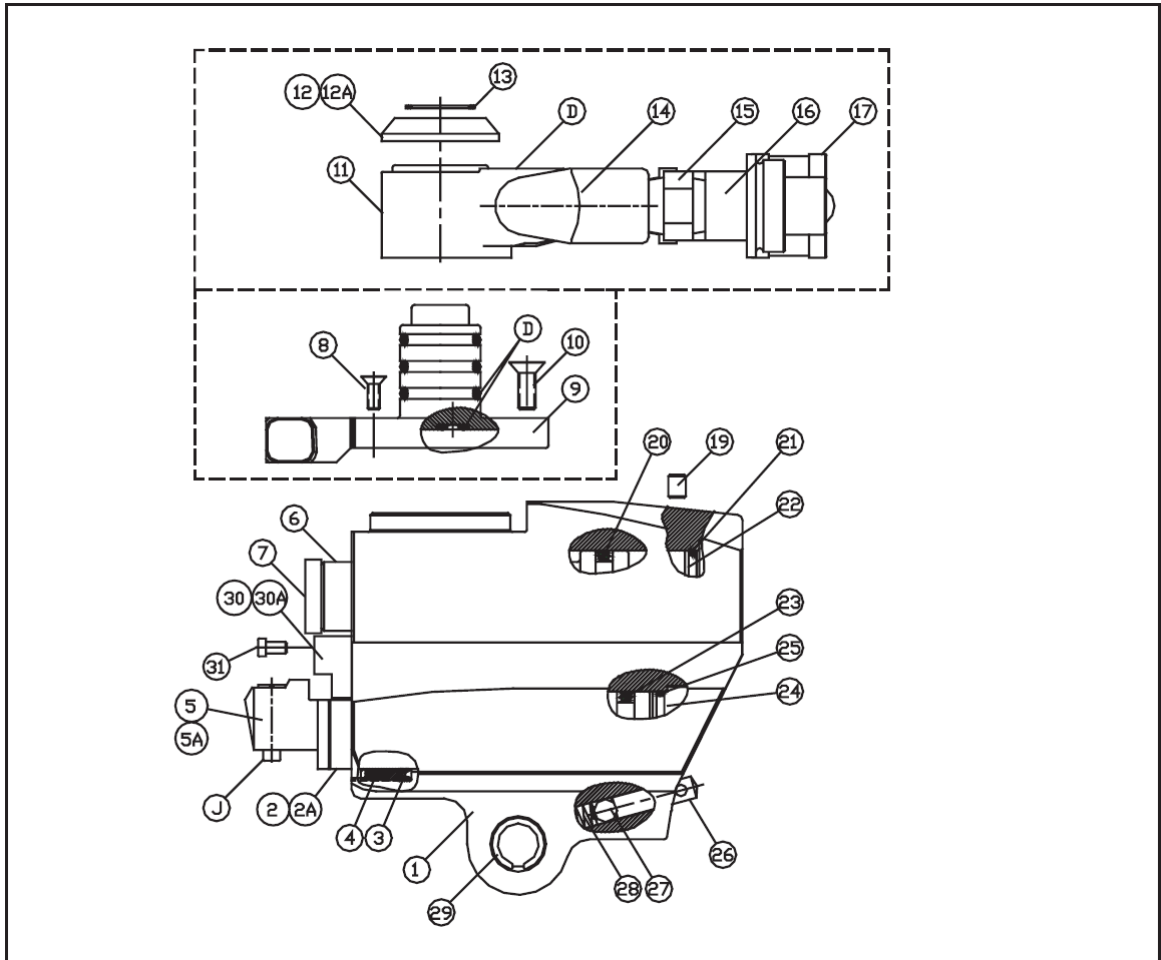

ITEM	DESCRIPTION	STEALTH 2	STEALTH 4	STEALTH 8	STEALTH 14	STEALTH 22	STEALTH 36
1	HOUSING			-- REFER TO KITS BELOW --			
2	BOTTOM PISTON-ROD	ST-02-03B	ST-04-03B	ST-08-03B	ST-14-03B	ST-22-03B	ST-36-03B
2A	BOTTOM PISTON-ROD AUTOMATIC	ST-02-03BA	ST-04-03BA	ST-08-03BA	ST-14-03BA	ST-22-03BA	ST-36-03BA
3	HOUSING SEAL			-- REFER TO KITS BELOW --			
4	ROD BUSHING	ST-02-15	ST-04-15	ST-08-15	ST-14-15	ST-22-15	ST-36-15
5	BOTTOM ROD-END HOOK	ST-02-04B	ST-04-04B	ST-08-04B	ST-14-04B	ST-22-04B	ST-36-04B
5A	BOTTOM ROD-END HOOK AUTOMATIC	ST-02-04BA	ST-04-04BA	ST-08-04BA	ST-14-04BA	ST-22-04BA	ST-36-04BA
6	TOP ROD-PISTON	ST-02-03T	ST-04-03T	ST-08-03T	ST-14-03T	ST-22-03T	ST-36-03T
7	TOP ROD-END	ST-02-04T	ST-04-04T	ST-08-04T	ST-14-04T	ST-22-04T	ST-36-04T
8	POST SCREWS	ST-02-13	ST-04-13	ST-08-13	ST-14-13	ST-22-13	ST-36-13
9	SWIVEL HOOK-POST	ST-002-HP	ST-004-HP	ST-008-HP	ST-014-HP	ST-022-HP	ST-036-HP
10	POST SCREWS	N/A	ST-04-14	ST-08-14	N/A	N/A	N/A
11	SWIVEL BLOCK	ST-002-BL	ST-004-BL	ST-004-BL	ST-004-BL	ST-022-BL	ST-022-BL
12	SAFETY CAP	ST-002-SC	ST-004-SC	ST-004-SC	ST-004-SC	ST-022-SC	ST-022-SC
12A	SAFETY CAP AUTOMATIC	ST-002-SCA	ST-004-SCA	ST-004-SCA	ST-004-SCA	ST-022-SCA	ST-022-SCA
13	SAFETY CAP RETAINING RING	MXT-01-504	MXT-03-504	MXT-03-504	MXT-03-504	MXT-10-504	MXT-10-504
14	SWIVEL KNUCKLE (ADV./RET.)	ST-004-KA/-KR	ST-004-KA/-KR	ST-004-KA/-KR	ST-004-KA/-KR	ST-022-KA/-KR	ST-022-KA/-KR
15	HEX NIPPLE (1/4-1/4)	090101	090101	090101	090101	090101	090101
16	COUPLER-M	090155	090155	090155	090155	090155	090155
17	COUPLER-F	090156	090156	090156	090156	090156	090156
18	SET SCREW PLUG			-- REFER TO KITS BELOW --			
19	SET SCREW PLUG			-- REFER TO KITS BELOW --			
20	TOP PISTON SEAL			-- REFER TO KITS BELOW --			
21	TOP CAP SEAL			-- REFER TO KITS BELOW --			
22	TOP CAP	ST-02-02T	ST-04-02T	ST-08-02T	ST-14-02T	ST-22-02T	ST-36-02T
23	BOTTOM PISTON SEAL			-- REFER TO KITS BELOW --			
24	BOTTOM CAP	ST-02-02B	ST-04-02B	ST-08-02B	ST-14-02B	ST-22-02B	ST-36-02B
25	BOTTOM CAP SEAL			-- REFER TO KITS BELOW --			
26	RELEASE PIN	ST-02-10-01	ST-04-10-01	ST-08-10-01	ST-14-10-01	ST-22-10-01	ST-36-10-01
27	RELEASE PIN	ST-02-10-02	ST-04-10-02	ST-08-10-02	ST-14-10-02	ST-22-10-02	ST-36-10-02
28	RELEASE SPRING	ST-02-10-03	ST-04-10-03	ST-08-10-03	ST-14-10-03	ST-22-10-03	ST-36-10-03
29	LINK PIN RETAINER	ST-02-19	ST-04-19	ST-08-19	ST-14-19	ST-22-19	ST-36-19
30	ANTI-ROTATION BLOCK			-- REFER TO KITS BELOW --			
30A	ANTI-ROTATION BLOCK AUTOMATIC WITH WIRE			-- REFER TO KITS BELOW --			
31	SOCKET CAP SCREW			-- REFER TO KITS BELOW --			
<b>ASSEMBLIES AND KITS</b>							
A	HOUSING ASSEMBLY ITEMS 1,3,4,18,19,21,22,24,25,29	ST-02-01	ST-04-01	ST-08-01	ST-14-01	ST-22-01	ST-36-01
B	UNISWIVEL BLOCK ASSEMBLY ITEMS 11,12,13,14,15,16,17	ST-002-BL	ST-004-BL	ST-004-BL	ST-004-BL	ST-022-BL	ST-022-BL
B2	UNISWIVEL BLOCK ASSEMBLY AUTOMATIC- ITEMS 11,12A,13,14,15,16,17	ST-002-BLA	ST-004-BLA	ST-004-BLA	ST-004-BLA	ST-022-BLA	ST-022-BLA
C	UNISWIVEL ASSEMBLY w/ POST ITEMS 9,9,10,8	ST-002	ST-004	ST-008	ST-014	ST-022	ST-036
C2	UNISWIVEL ASSEMBLY w/ POST AUTOMATIC-ITEMS 9,9,10,8,2	ST-002A	ST-004A	ST-008A	ST-014A	ST-022A	ST-036A
D	UNISWIVEL SEAL KIT	ST-002-00	ST-004-00	ST-004-00	ST-004-00	ST-022-00	ST-022-00
E	HOUSING SEAL KIT ITEMS 3,20,21,23,25	ST-02-62	ST-04-62	ST-08-62	ST-14-62	ST-22-62	ST-36-62
F	HOUSING MAINTENANCE KIT ITEMS 15,16,17,18,19,29,E,K,G	MK-ST2	MK-ST4	MK-ST8	MK-ST14	MK-ST22	MK-ST36
G	RELEASE-PIN KIT ITEMS 26,27,28	ST-02-10	ST-04-10	ST-08-10	ST-14-10	ST-22-10	ST-36-10
H	TOP PISTON-ROD ASSEMBLY ITEMS 2,5,23,J	ST-02-06T	ST-04-06T	ST-08-06T	ST-14-06T	ST-22-06T	ST-36-06T
I	BOTTOM PISTON-ROD ASSEMBLY ITEMS 2,5,23,J	ST-02-06B	ST-04-06B	ST-08-06B	ST-14-06B	ST-22-06B	ST-36-06B
I2	BOTTOM PISTON-ROD ASSEMBLY AUTOMATIC-ITEMS 2A,5A,23,J	ST-02-06BA	ST-04-06BA	ST-08-06BA	ST-14-06BA	ST-22-06BA	ST-36-06BA
J	ROD END HOOK PIN KIT	ST-02-09	ST-04-09	ST-08-09	ST-14-09	ST-22-09	ST-36-09
K	ANTI-ROTATION KIT ITEMS 30,31	ST-02-05	ST-04-05	ST-08-05	ST-14-05	ST-22-05	ST-36-05
K2	ANTI-ROTATION KIT AUTOMATIC ITEMS 30A,31	ST-02-05A	ST-04-05A	ST-08-05A	ST-14-05A	ST-22-05A	ST-36-05A

# Hytorc-Stealth sprängskiss

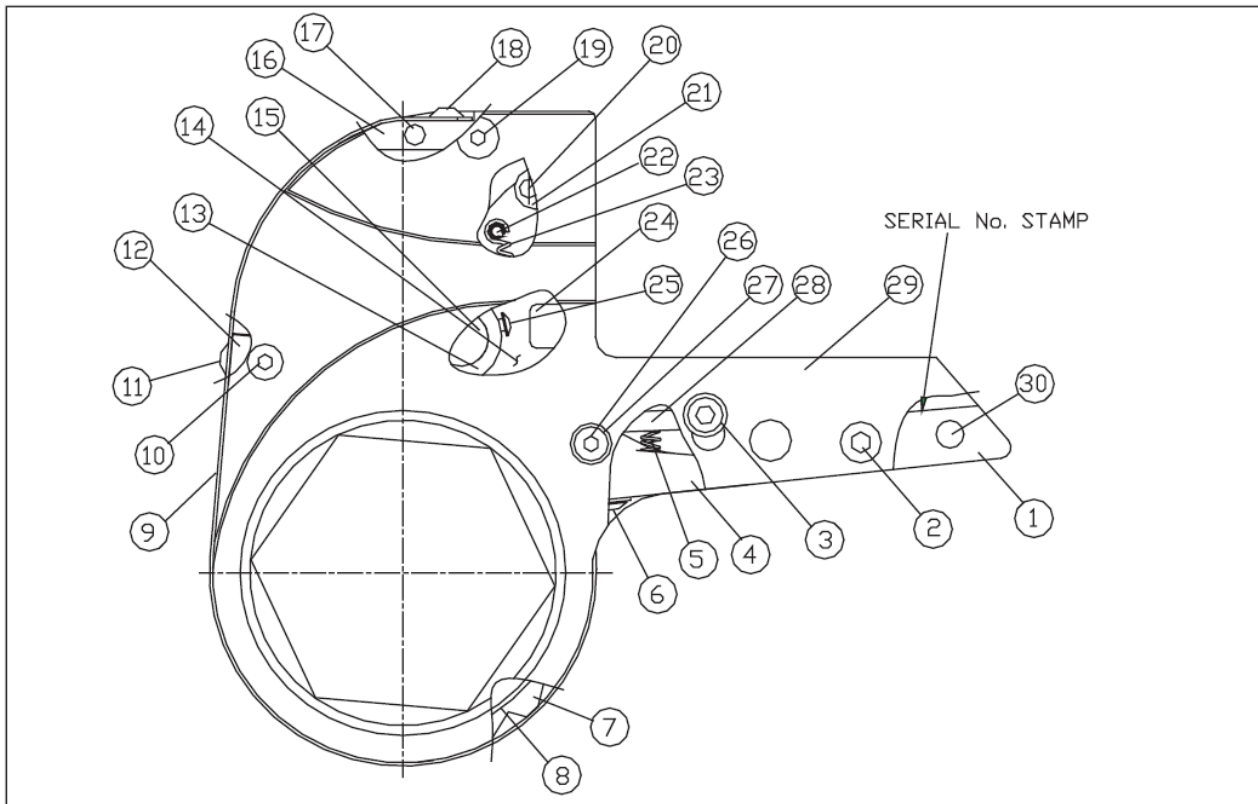

ITEM	DESCRIPTION	QTY	STEALTH 2	STEALTH 4	STEALTH 8	STEALTH 14	STEALTH 22	STEALTH 36
1	LOWER REAR SPACER	1	ST-02-45R	ST-04-45R	ST-08-45R	ST-14-45R	ST-22-45R	ST-36-45R
2	SIDE PLATE SCREW-REAR	2	ST-02-50	ST-04-50	ST-08-50	ST-14-50	ST-22-50	ST-36-50
3	RELEASE BUTTON, R-PAWL	2	ST-02-39	ST-04-39	ST-08-39	ST-14-39	ST-22-39	ST-36-39
4	LOWER FRONT SPACER	1	ST-02-45F-#	ST-04-45F-#	ST-08-45F-#	ST-14-45F-#	ST-22-45F-#	ST-36-45F-#
5	SPRING, REACTION SPACER	1	ST-02-37	ST-04-37	ST-08-37	ST-14-37	ST-22-37	ST-36-37
6	SHROUD SCREW, BOTTOM	1	ST-02-23	ST-04-23	ST-08-23	ST-14-23	ST-22-23	ST-36-23
7	RAITCHET, HEX SIZE	1	ST-02-28-*	ST-04-28-*	ST-08-28-*	ST-14-28-*	ST-22-28-*	ST-36-28-*
8	SIDE PLATE BRONZE SLEEVE	2	ST-02-29-#	ST-04-29-#	ST-08-29-#	ST-14-29-#	ST-22-29-#	ST-36-29-#
9	SHROUD	1	ST-02-43-#	ST-04-43-#	ST-08-43-#	ST-14-43-#	ST-22-43-#	ST-36-43-#
10	SMALL SIDE PLATE SCREW	2	ST-02-51	ST-04-51	ST-08-51	ST-14-51	ST-22-51	ST-36-51
11	MID SPACER SHROUD SCREW	2	N/A	N/A	N/A	ST-14-25	ST-22-25	ST-36-25
12	MIDDLE SPACER	1	ST-02-45M	ST-04-45M	ST-08-45M	ST-14-45M	ST-22-45M	ST-36-45M
13	DRIVE PAWL	1	ST-02-22-#	ST-04-22-#	ST-08-22-#	ST-14-22-#	ST-22-22-#	ST-36-22-#
14	DRIVE PLATE (LH, RH)	1ea	ST-02-35-#	ST-04-35-#	ST-08-35-#	ST-14-35-#	ST-22-35-#	ST-36-35-#
15	DRIVE PAWL PIN	1	ST-02-20	ST-04-20	ST-08-20	ST-14-20	ST-22-20	ST-36-20
16	TOP SPACER	1	ST-02-45T	ST-04-45T	ST-08-45T	ST-14-45T	ST-22-45T	ST-36-45T
17	DOWL PIN, SPACERS	2	ST-02-48	ST-04-48	ST-08-48	ST-14-48	ST-22-48	ST-36-48
18	TOP SHROUD SCREW	1	ST-02-24	ST-04-24	ST-08-24	ST-14-24	ST-22-24	ST-36-24
19	TOP SIDE PLATE SCREW	2	ST-02-49	ST-04-49	ST-08-49	ST-14-49	ST-22-49	ST-36-49
20	SLIDE HOOK PIN	4	ST-02-32	ST-04-32	ST-08-32	ST-14-32	ST-22-32	ST-36-32
21	SLIDE, UPPER	1	ST-02-30	ST-04-30	ST-08-30	ST-14-30	ST-22-30	ST-36-30
22	ROLL PIN, DR. PAWL SPRING	1	ST-02-33	ST-04-33	ST-08-33	ST-14-33	ST-22-33	ST-36-33
23	DRIVE PAWL SPRING	1	ST-02-27	ST-04-27	ST-08-27	ST-14-27	ST-22-27	ST-36-27
24	SLIDE, BOTTOM	1	ST-02-31	ST-04-31	ST-08-31	ST-14-31	ST-22-31	ST-36-31
25	SCREW, DRIVE PAWL SPRING	1	ST-02-26	ST-04-26	ST-08-26	ST-14-26	ST-22-26	ST-36-26
26	BOTTOM SIDE PLATE SCREW	2	ST-02-53	ST-04-53	ST-08-53	ST-14-53	ST-22-53	ST-36-53
27	PIN, REACTION PAWL	1	ST-02-38	ST-04-38	ST-08-38	ST-14-38	ST-22-38	ST-36-38
28	REACTION PAWL	1	ST-02-36-#	ST-04-36-#	ST-08-36-#	ST-14-36-#	ST-22-36-#	ST-36-36-#
29	LINK SIDE PLATE (LH, RH)	1ea	ST-02-52-#	ST-04-52-#	ST-08-52-#	ST-14-52-#	ST-22-52-#	ST-36-52-#
30	DOWL PIN, REAR SPACER	1	ST-02-34	ST-04-34	ST-08-34	ST-14-34	ST-22-34	ST-36-34
<b>ASSEMBLIES AND KITS</b>								
A	DRIVE PAWL ASSY KIT ITEMS: 13,15,22,23,25		ST-02-21-*	ST-04-21-*	ST-08-21-*	ST-14-21-*	ST-22-21-*	ST-36-21-*
B	LINK MAINTENANCE KIT ITEMS: 2,3,5,6,10,11,17,18,19,20,22,23,25,26,27,30		MK-ST2LK	MK-ST4LK	MK-ST8LK	MK-ST14LK	MK-ST22LK	MK-ST36LK

REPLACE # WITH LINK BLANK SIZE.  
 REPLACE \* WITH HEX SIZE.  
 BLANK SIZE IS STAMPED NEAR TOP OUTSIDE OF LINK.